



## Sample Reports & Logs



[www.fitnessincentive.com](http://www.fitnessincentive.com)

# Jump Start: Personal Training

## Fitness Analysis

Sample Fitness Assessment Report & Graph

**Healthy Living**

Fitness Assessments for Jenny Jumpstart

SUMMARY FITNESS SCORE	Date	Score	Rank	Rating
Average Fitness Test Rank	1/10/2004		38	Fair
	3/25/2004		53	Average
	7/31/2004		71	Above Avg
	Goal		83	Excellent
Change in Average Rank			86%	

  

BODY COMPOSITION TESTS				
Weight (lbs)	1/10/2004	168.0		
	3/25/2004	158.0		
	7/31/2004	146.0		
	Goal:	140.0		
Change in Raw Score:		-13%		
Bodyfat (direct entry) (%)	1/10/2004	35.0	12	Risky
	3/25/2004	32.0	24	Fair
	7/31/2004	28.0	41	Average
	Goal:	24.9	55	Average
Change in Raw Score/Rank:		-20%	241%	
Waist-Hip Ratio	1/10/2004	0.7	81	Excellent
	3/25/2004	0.7	86	Excellent
	7/31/2004	0.7	97	Excellent
	Goal:	0.6	99	Excellent
Change in Raw Score/Rank:		-4%	19%	
Height (In)	1/10/2004	66.0		
	3/25/2004	66.0		
	7/31/2004	66.0		
	Goal:	0.0		
Change in Raw Score:		0%		

CARDIOVASCULAR CAPACITY TESTS				
Resting Heart Rate (BPM)	1/10/2004	72.0	51	Average
	3/25/2004	68.0	62	Above Avg
	7/31/2004	65.0	71	Above Avg
	Goal:	61.0	84	Excellent
Change in Raw Score/Rank:		-9%	39%	

Before we can develop a training program for you, your personal trainer will meet with you to get an understanding of both your fitness goals and your current physical fitness. Your trainer will measure your fitness by conducting a series of tests and measurements to determine your strength, flexibility, and aerobic capacity. They'll also take extensive measurements, including body fat percentage, weight, hip to waist ratio, and blood pressure. Using this data, they'll create a report card of your physical fitness. You and your trainer will decide upon short-term and long-term goals that you will work towards, together. Your progress will be re-evaluated mid-program, and then, at the end of the program, you'll get your final progress report. This will show the improvements you've made against all the measures of fitness... **the results!**

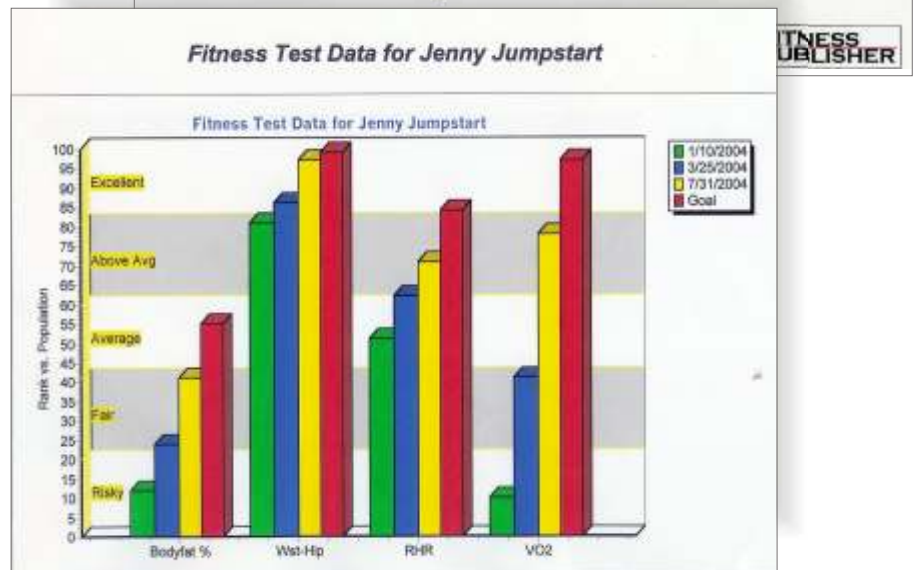

# Jump Start: Personal Training

2

## One-on-One Training

Sample Page from Exercise Program

### Exercises for Jenny Jumpstart

#### 45 Degree Leg Sled Press

A) Adjust angle of back support so hip position is comfortable.  
 B) Sit and position feet straight ahead with big toes just inside hip width.  
 C) Place hands on handles, with head, shoulders, and low back positioned firmly against pad.  
 D) Press low back against pad. Bend knees and lower the weight until the upper and lower leg form a 90 degree angle (do not allow buttocks to rise off seat).  
 E) Keep knee caps over feet and heels in contact with platform as you bend, and then straighten legs to a soft lock position (5-10 degrees of knee flexion).

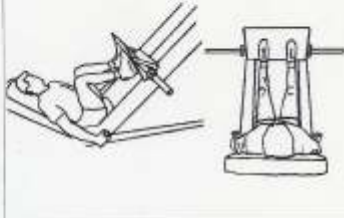

Weight: 75.0 Reps: 12 Sets: 2 For 6 weeks, 2 times/week Position: Narrow foot  
 Actual Date: \_\_\_\_\_  
 Actual Weight/Reps/Sets: \_\_\_\_\_

#### Machine Full Knee Flexion

A) Lie on stomach with hips positioned higher than knees and grip handles of machine.  
 B) Position leg pad above heels and below calf muscles, with knee caps just off the edge of thigh seat.  
 C) Align feet just inside hip width and straighten legs.  
 D) Pull toes toward shins and touch big toes together.  
 E) Bend knees and keep big toes together for first half of exercise. Allow the lower legs to progressively rotate so the toes end angled slightly outward.



Weight: 25.0 Reps: 12 Sets: 2 For 6 weeks, 2 times/week  
 Actual Date: \_\_\_\_\_  
 Actual Weight/Reps/Sets: \_\_\_\_\_

**P**ersonal Training is the a core component of the Jump Start program. Your personal trainer will work with you - one-on-one - every week of the program. They will develop an exercise routine for you that will get you to your fitness goals. They'll show you the proper form for every exercise. You'll learn your resting heart rate (RHR) and how to perform cardio work in the proper heart rate "zones". And they'll help evolve your program as you progress, making sure that you stay challenged and "on-course" for the entire twelve weeks. They'll also give you weekly assignments - exercises you should be doing when you're not training with them. You'll be provided with a log to track your daily fitness (and diet) activities, and your trainer will review this book every week to keep track of you progress and commitment. You'll also get an illustrated set of recommended exercises, something you can refer to when you're working out on your own.

**A**t the end of the program, you'll be re-evaluated, and a fitness "report card" will be created. It will show you exactly where you were at the start of the program, and where you are at the end. And more; you'll graduate with the knowledge and experience to continue with your fitness program for the rest of your life. **Prepare to be amazed.**

Sample Page from the Daily Diet & Exercise Log



Date: \_\_\_\_\_ Day: \_\_\_\_\_ Weight: \_\_\_\_\_

Food or Beverage	Amount	Grams of				
		Calories	Fat	Carbs	Protein	Fiber
<b>Breakfast</b>	Notes: _____					
<b>Time:</b>	<b>Totals &gt;</b>					
<b>Lunch</b>	Notes: _____					
<b>Time:</b>	<b>Totals &gt;</b>					
<b>Dinner</b>	Notes: _____					
<b>Time:</b>	<b>Totals &gt;</b>					
<b>Snack / Time (M, A, E)</b>	Notes: _____					
<b>Totals &gt;</b>						
<b>Days Totals:</b>						
<b>Physical Activity</b>	Hrs/Min	Qty	Sets	Intensity (1-20)	Calories	
<b>Days Totals:</b>						

Notes: \_\_\_\_\_ PT OK: \_\_\_\_\_

# Jump Start: Eat Smart!

Sample 3 Day Dietary Analysis

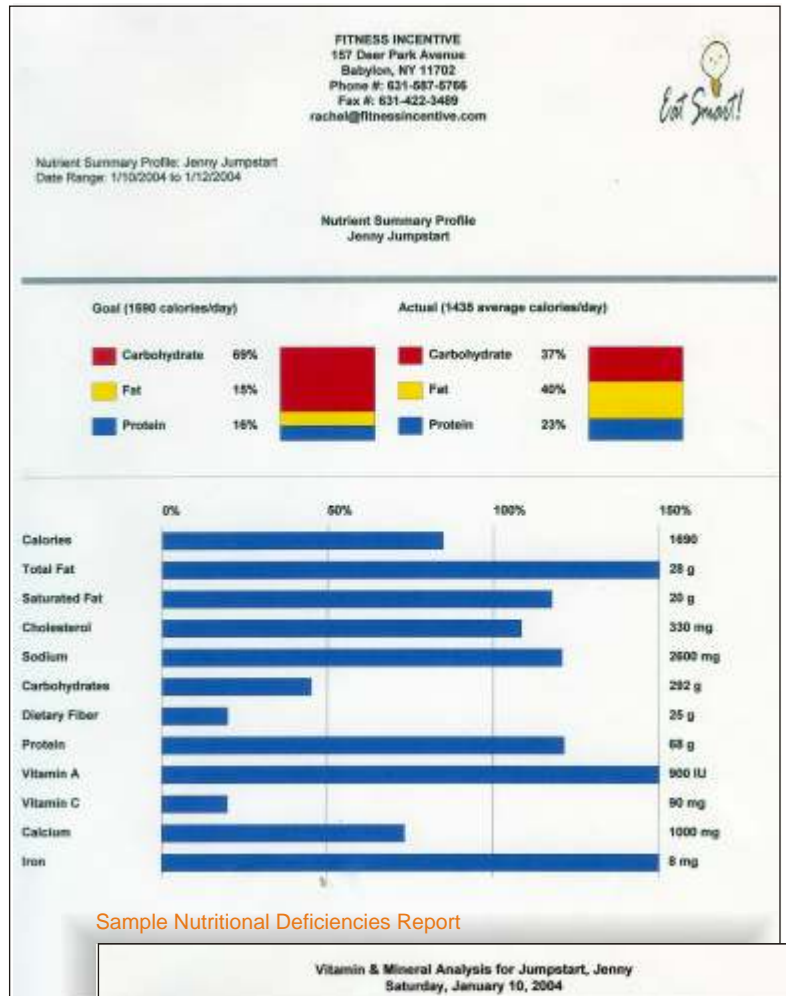

Sample Nutritional Deficiencies Report

Understanding your how your diet affects your weight management, health, and fitness goals is critical in designing your Jump Start program. Our “Eat Smart” dietary analysis builds on the information we gathered through Metacheck by utilizing a detailed questionnaire that documents your diet and fitness for three days. After completing the questionnaire you will review the results with your Eat Smart Coordinator who will provide you with a full color nutritional profile showing the strengths and weaknesses of your current diet.

You’ll receive a full report of your current nutrition, as well as a comparison to the ideal. (see sample report above right) as well as a nutritional deficiencies analysis (sample lower right).

Now we have the information we need to re-design your diet!

**Vitamin & Mineral Analysis for Jumpstart, Jenny**  
Saturday, January 10, 2004

Nutrient	RDA	Actual	Difference
Vitamin A (IU)	900	744	-156
Thiamin (mg)	1	1	0
Riboflavin (mg)	1	1	0
Niacin (mg)	16	22	6
Vitamin B6 (mg)	1	2	0
Vitamin B12 (mcg)	2	6	4
Fat (mcg)	400	328	-72
Vitamin C (mg)	90	14	-76
Calcium (mg)	1000	275	-725
Iron (mg)	8	11	3
Magnesium (mg)	425	184	-241
Potassium (mg)	2000	1925	-75
Zinc (mg)	11	14	3

# Jump Start: Eat Smart!

2

## Sample Goals & Tracking

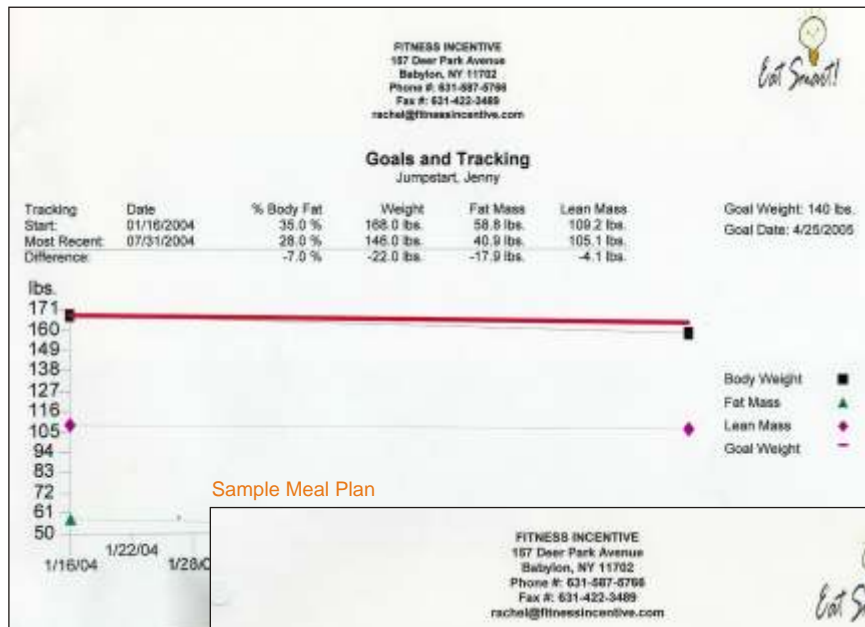

## Sample Meal Plan

**FITNESS INCENTIVE**  
157 Deer Park Avenue  
Babylon, NY 11702  
Phone #: 631-687-5798  
Fax #: 631-422-3489  
rachel@fitnessincentive.com

**Meal Planner For:** Jumpstart, Jenny  
**For the Date Range:** 01/19/2004 to 01/20/2004

**DAY # 1**  
(01/19/2004)

Qty	Measure	Description	Protein(g)	Carb(g)	Fat(g)	Calories
<b>Breakfast</b>						
0.5	1 cup	Egg substitute, liquid	15.96	0.90	4.15	105.42
1	1 muffin	English muffin, whole-wheat, toasted	3.58	28.93	1.42	134.81
1	cup	Silk Plain Soy Milk	7.50	8.00	4.90	130.50
		<b>Totals</b>	<b>27.02</b>	<b>38.70</b>	<b>9.98</b>	<b>340.25</b>
<b>AM Snack</b>						
1	1 cup	Grapes, american type (slp skin), raw	0.58	15.70	0.32	61.84
1	1 muffin (2-1/2" dia x 2-1/4")	Muffin, oat bran	3.99	27.53	4.22	153.90
1	tblsps	SMART BALANCE Buttery Spread	0.00	0.00	3.00	36.67
		<b>Totals</b>	<b>4.57</b>	<b>43.23</b>	<b>7.54</b>	<b>342.21</b>
<b>Lunch</b>						
0	medium	Carrots - baby, raw	0.80	8.40	0.90	32.00
2.5	normal	CONDENSED KETCHUP, Veggie Medley	8.09	17.00	0.70	100.00
1	tblsps	HUMI'S Tonsito Ketchup No Salt Added	0.23	3.45	0.13	19.80
1	each	Pita - wheat	2.80	15.60	0.70	75.00
0.5	1 cup	Spinach, raw	0.43	0.53	0.05	3.30
1	1 cup, whole	Strawberries, raw	0.84	10.11	0.53	43.20
2	1 slice, medium (1/4" thick)	Tomatoes, red, ripe, raw, year round average	0.34	1.86	0.13	8.40
		<b>Totals</b>	<b>11.48</b>	<b>54.94</b>	<b>5.05</b>	<b>277.80</b>
<b>PM Snack</b>						
3	each	Mdln Toast, Wheat Unleaded	2.00	11.00	0.00	60.00
6	tblsps	Vegetable juice - V8, no salt	1.00	8.00	0.00	30.00
		<b>Totals</b>	<b>3.00</b>	<b>19.00</b>	<b>0.00</b>	<b>90.00</b>
<b>Dinner</b>						
1	0.5 cup	Broccoli, frozen, spears, cooked, boiled, drained, without salt	2.85	4.82	0.10	25.75
1	1 fillet	cod, Atlantic, cooked, dry heat	41.00	0.70	1.55	189.00
2	tblsps	Oil & Vinegar Salad Dressing	0.00	0.28	5.22	46.70
0.5	large	Salad - 1/2 garden w/tomato & onion	1.30	0.50	0.40	49.00
1	tblsps	SMART BALANCE Buttery Spread	0.00	0.00	3.00	36.67
1	cup	Yam - baked or boiled	2.00	37.80	0.20	150.00
		<b>Totals</b>	<b>47.25</b>	<b>52.38</b>	<b>10.47</b>	<b>486.19</b>
<b>Actual Totals for 01/19/2004:</b>			<b>94.21</b>	<b>205.23</b>	<b>38.61</b>	<b>1440.43</b>
<b>Actual % of Total Calories:</b>			<b>28.88</b>	<b>65.72</b>	<b>18.70</b>	

The "Diet Rx" is the key nutritional component of the Jump Start program. It takes information that we've learned about your diet from the dietary analysis and Metacheck and uses it to build a complete dietary program. Diet Rx includes: individualized recommended nutritional intakes, meal plans (with an exchange list), recipes, shopping lists, regular weigh-ins, and follow-up counseling sessions in weeks eight and twelve.

But there's more to jump start than simply redesigning your diet. There's a fitness analysis and personal training component designed to take the whole process to another level...

# Jump Start: Metacheck

Sample Metacheck Report

**M**etacheck is a state-of-the-art metabolism test. It measures your resting metabolic rate (RMR) - the amount of calories you personally burn every 24 hours - with 97% accuracy. Metacheck also calculates how many calories you will additionally burn from exercise and daily activities, and tells us whether your metabolism is slow, average or fast. This information is critical, because whether you need to add lean mass, lose body fat or both, your personal caloric expenditure needs to be taken into consideration when developing your diet and exercise programs.

In Jump Start, this information (see report on right) is used by your Personal Trainer and Eat Smart Counselor to tailor the program specifically to you.

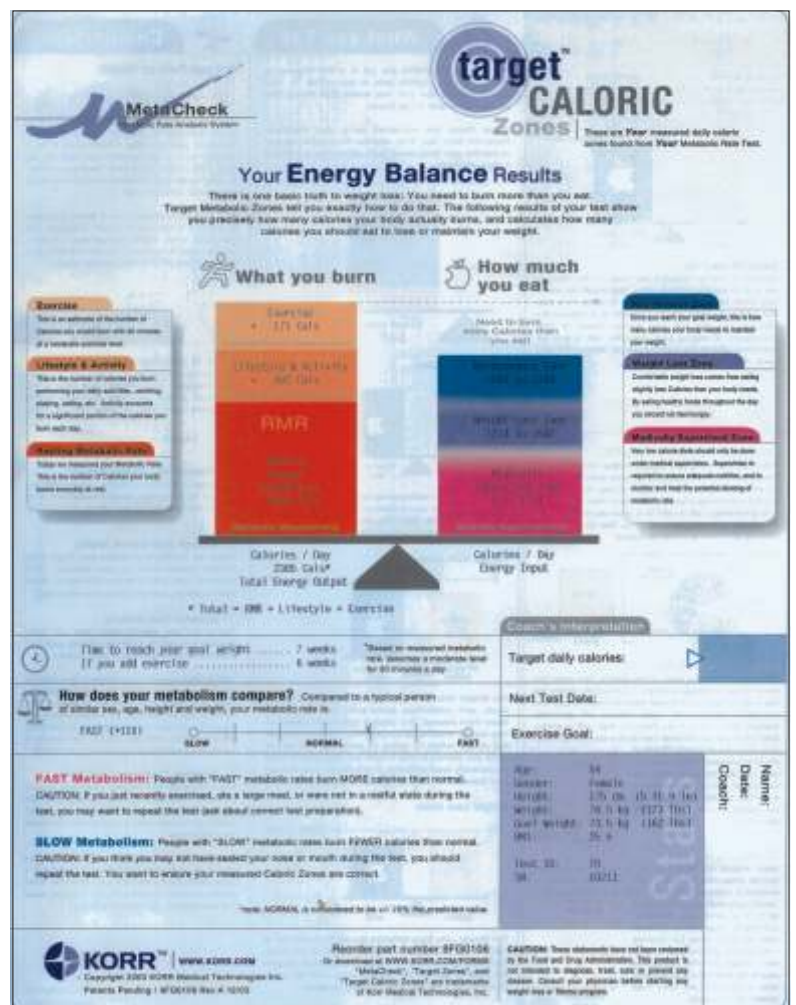



# Jump Start: Body Composition

2

Sample Body Composition Report

**B**ody composition testing takes us beyond how much you weigh - it tells us what, exactly, those pounds are composed of: lean muscle versus body fat\*. The body composition test also allows us to create short-term and long-term goals! (usually requiring a decrease of body fat and an increase in lean mass). We continually track your progress towards this goal. (see report sample on right.)

An increase in lean muscle has the added benefit of increasing RMR, meaning you'll burn more calories, even when at rest.

\*The analysis shows body fat and lean mass as a percentage of the total body weight. For example, a 150 lb. female's body fat could be 35% (unhealthy) or 25% (healthy). All pounds are NOT equal!

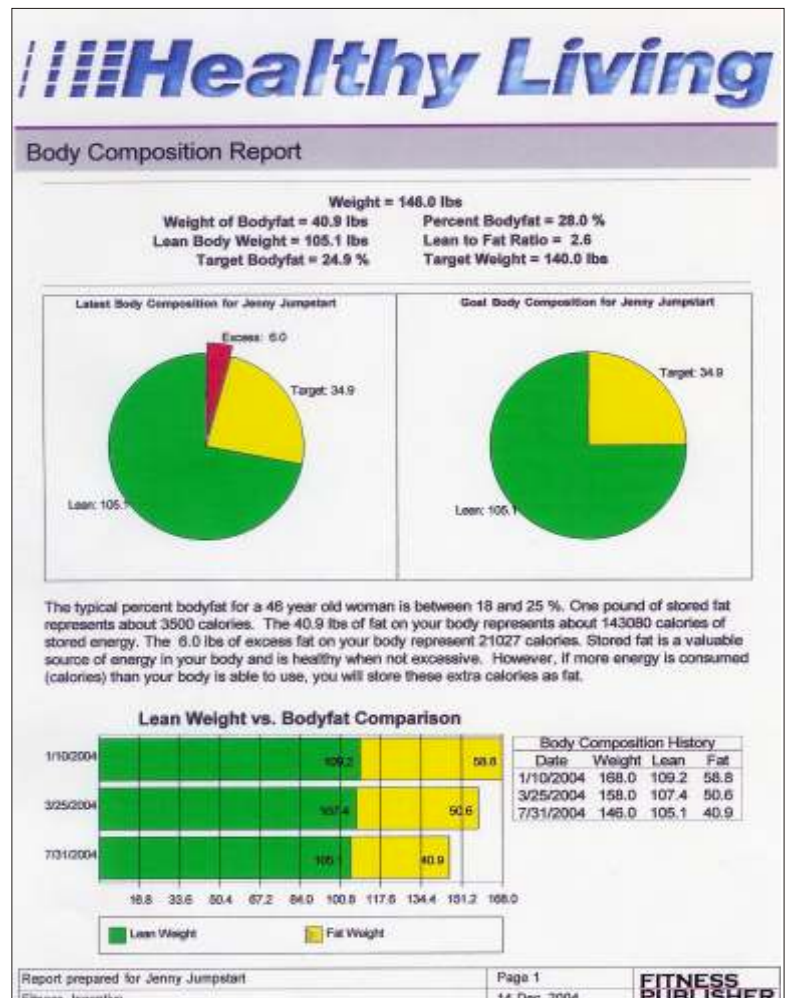



## Twelve Weeks. Guaranteed Results.\*

**S**o you've made the commitment...or you're at least thinking about it. "This year I'll get serious. This year I'll really get back in shape, take control of my health." But there are those nagging doubts: "this health and fitness stuff sounds great but it's going to take a lot of time and effort - and how do I really know if I'll even get the results I want?" It's a common problem. You know - we all know - that a healthy diet and regular exercise are the keys. But what do you really know about diet and exercise?

Now there's help. It's called Jump Start, and we invented it for one reason: **we want you to get what you came here for - results!** Jump Start works because it is completely about *you* - your body, your diet, your goals. For twelve weeks you'll work one-on-one with diet and fitness professionals. They'll start out by learning just about everything there is to know about your current state of fitness and your current diet. They discuss and help you to develop reasonable, attainable goals. Then, armed with this information, they'll develop a diet and exercise plan specifically for *you*. No off-the-shelf diets, no magic pills or new-fangled machines - just a sensible, sustainable approach to diet and exercise.

Then the work begins - implementing the plan. And again, your team of experts is there with you, all the way. Failure is not an option. You'll workout every week with your personal trainer. You'll meet regularly with our diet coordinator to review your progress and fine-tune your meal plan. And then, at the end of the twelve week program, we'll measure your progress by giving you a complete re-evaluation. You'll be able to compare the new you to the old you. And we promise - *guarantee\** - that you'll see results. And more; you'll graduate from Jump Start with the knowledge and experience you need to make healthy eating and regular exercise a permanent part of your life.

So what are you waiting for? The time for action is at hand - get ready to change your life with Jump Start!

\*Our guarantee: Fitness Incentive guarantees that by the end of the Jump Start program you will lose inches and/or gain strength, as determined by your goals (indicated at the start of the program) and as measured against your original fitness evaluation. If you fail to either lose inches and/or gain strength, you have your choice of either repeating the program for free or receiving a refund of your Jump Start fee. To qualify, you must comply with the program fully and you must keep the diet and exercise logs provided by Fitness Incentive and required by the Jump Start program. There is a maximum of one repeat or refund allowed per participant. The Jump Start program and this guarantee applies only to Fitness Incentive members.



## Program Summary and Pricing

### Program Content:

#### **Metacheck Metabolism Test & Reports, including:**

- Resting Metabolic Rate (RMR)
- Projected Caloric Expenditure
- Recommended Caloric Intake

#### **Body Composition Analysis and Report, including:**

- Lean Weight vs. Body Fat
- Current and Target Body Composition Comparison

#### **“Eat Smart” Dietary Assessment and Reports, including:**

- Nutrient Summary Profile of Current Diet
- Vitamin and Mineral Deficiencies
- Body Measurements and Goal Tracking
- Complete Meal Plans, Recipes, and Shopping Lists
- Follow-up Progress Tracking and Dietary Fine Tuning Meetings

#### **Fitness Assessment Testing and Progress Tracking, including:**

- Body Fat Percentage
- Waist - Hip Ratio / Body Circumferences
- Resting Heart Rate
- VO<sub>2</sub> (Aerobic Capacity)
- Blood Pressure
- Body Weight

#### **Personal Training**

- Ten 45 Minute One-on-one Training Sessions with Your Personal Trainer
- Two Fitness Assessment Sessions with Your Personal Trainer
- Completely Customized Training Program Designed to Meet Your Fitness Goals
- 12 Week Fitness and Diet Tracking Diary (required for program guarantee)

### Program Cost:

The 12 week Jump Start program costs \$600. It can be paid in-full, or in 3 monthly installments of \$200.

Note: Installment payment plan requires a valid credit card be kept of file with Fitness Incentive.

### Program Rules:

#### **Members Only:**

You can purchase Jump Start as an add-on to any membership three months or longer in duration. Your membership must remain active while you are enrolled in the Jump Start program.

#### **Jump Start Guarantee:**

Fitness Incentive guarantees that by the end of the Jump Start program you will lose inches and/or gain strength, as determined by your goals (indicated at the start of the program) and as measured against your original fitness evaluations. If you fail to either lose inches and/or gain strength, you have your choice of either repeating the program for free or receiving a refund of your Jump Start fee. To qualify, you must comply with the program fully and you must keep the diet and exercise logs provided by Fitness Incentive and required by the Jump Start program. There is a maximum of one repeat or refund allowed per participant. The Jump Start program and this guarantee applies only to Fitness Incentive members.